

2HB 皮带式高压风机 / 气环式真空泵

2HB Belt type high pressure fan/gas ring vacuum pump



2HB 210-1HY99 参数及曲线

2HB 210-1HY99 parameters and the curve

NO	Rated Speed	Rated Power	Max air flow	Max vacuum	Max pressure	Sound-Level	Weight
编号	转速	配置功率	最大流量	最大真空	最大压力	噪音	重量
	PRM	KW	M ³ /h	mbar	mbar	db(A)	Kg
A	3000	0.7	80	-130	130	53	5.5
	3600	0.83	100	-160	160	56	
	4200	0.95	120	-170	170	60	
	5000	1.1	140	-180	170	62	

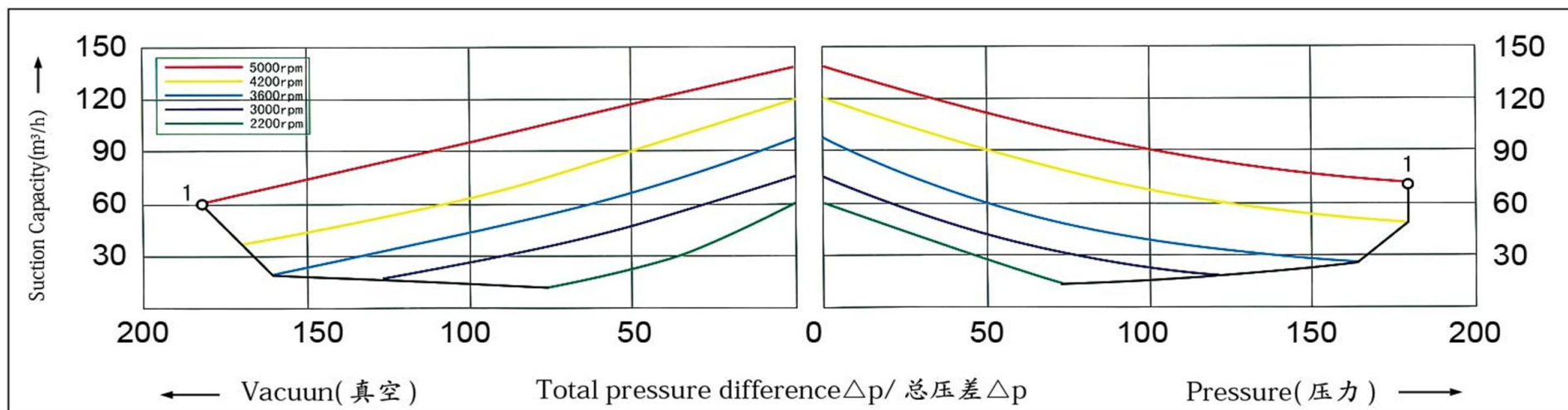

2HB 220-1HY99 参数及曲线

2HB 220-1HY99 parameters and the curve

NO	Rated Speed	Rated Power	Max air flow	Max vacuum	Max pressure	Sound-Level	Weight
编号	转速	配置功率	最大流量	最大真空	最大压力	噪音	重量
	PRM	KW	M ³ /h	mbar	mbar	db(A)	Kg
A	3000	0.7	85	-210	240	55	9
	3600	0.83	102	-260	290	61	
	4200	0.95	128	-290	280	64	
	5000	1.1	150	-220	230	66	

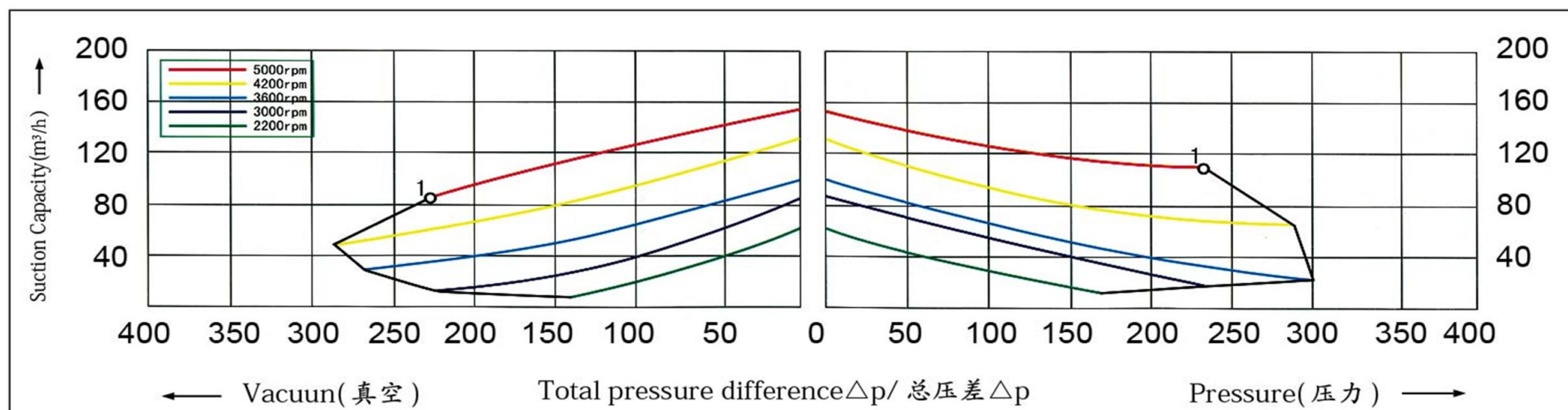

2HB 230-1HY99 参数及曲线

2HB 230-1HY99 parameters and the curve

NO	Rated Speed	Rated Power	Max air flow	Max vacuum	Max pressure	Sound-Level	Weight
编号	转速	配置功率	最大流量	最大真空	最大压力	噪音	重量
	PRM	KW	M ³ /h	mbar	mbar	db(A)	Kg
A	3000	0.7	105	-120	140	54	7
	3600	0.83	120	-160	180	57	
	4200	0.95	140	-220	230	60	
	5000	1.1	170	-210	190	63	

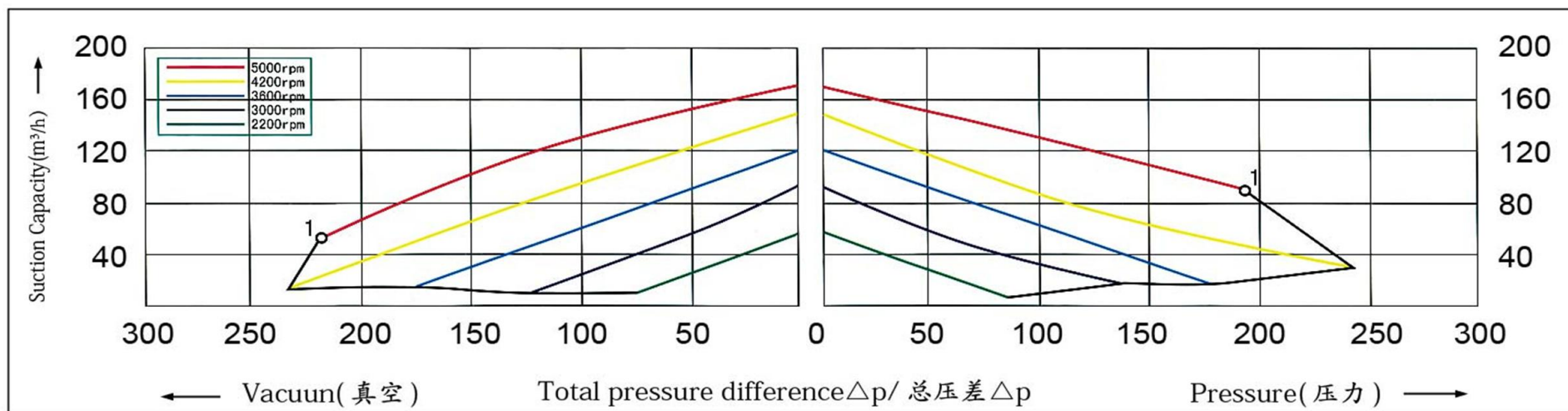

2HB 410-1HY99 参数及曲线

2HB 410-1HY99 parameters and the curve

NO	Rated Speed	Rated Power	Max air flow	Max vacuum	Max pressure	Sound-Level	Weight
编号	转速	配置功率	最大流量	最大真空	最大压力	噪音	重量
	PRM	KW	M ³ /h	mbar	mbar	db(A)	Kg
A	3000	0.85	150	-160	160	63	7.5
	3600	0.95	180	-160	160	64	
	4200	1.3	220	-180	180	68	
	5000	1.5	250	-140	130	74	
B	3000	1.3	150	-170	200	63	
	3600	1.5	180	-210	200	64	
	4200	1.75	220	-210	190	68	
	5000	2.1	250	-200	200	74	

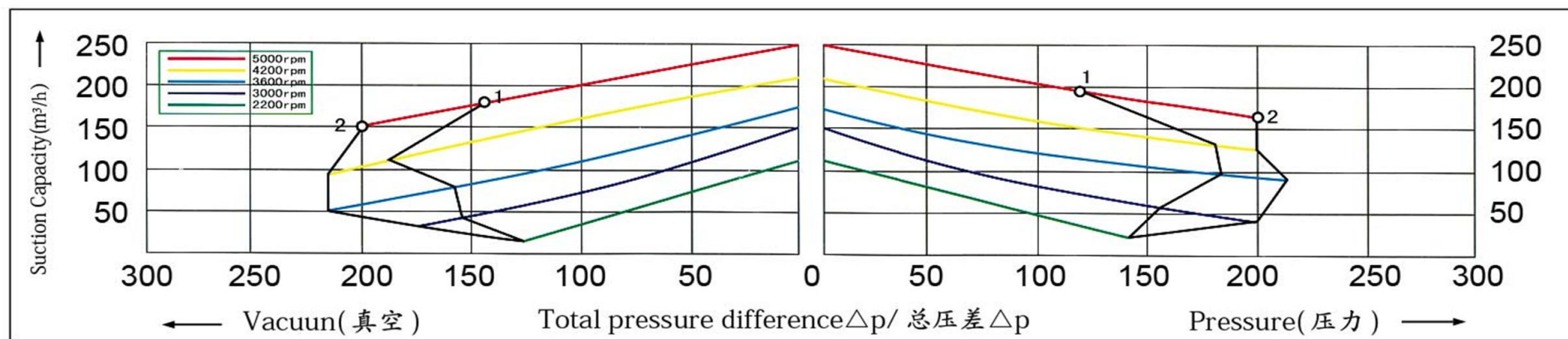

2HB 420-1HY99 参数及曲线

2HB 420-1HY99 parameters and the curve

NO	Rated Speed	Rated Power	Max air flow	Max vacuum	Max pressure	Sound-Level	Weight
编号	转速	配置功率	最大流量	最大真空	最大压力	噪音	重量
	PRM	KW	M ³ /h	mbar	mbar	db(A)	Kg
A	3000	2.2	160	-330	440	66	13.5
	3600	2.55	190	-350	420	69	
	4200	3	230	-420	400	72	
	5000	3.8	260	-380	330	77	

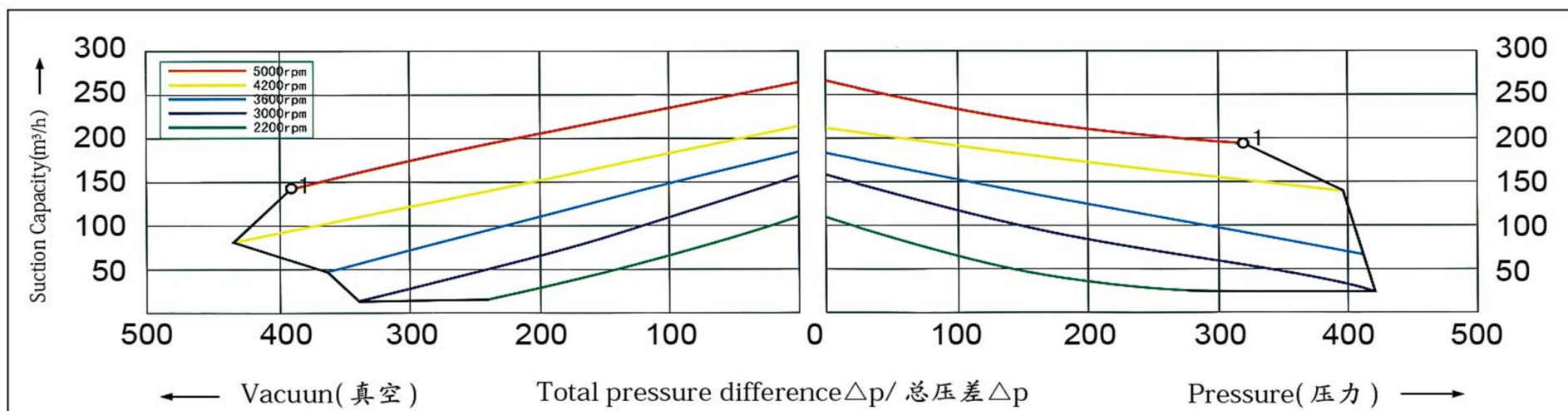

2HB 430-1HY99 参数及曲线

2HB 430-1HY99 parameters and the curve

NO	Rated Speed	Rated Power	Max air flow	Max vacuum	Max pressure	Sound-Level	Weight
编号	转速	配置功率	最大流量	最大真空	最大压力	噪音	重量
	PRM	KW	M ³ /h	mbar	mbar	db(A)	Kg
A	3000	1.3	180	-180	200	64	8.5
	3600	1.5	210	-210	240	65	
	4200	1.75	255	-240	230	69	
	5000	2.1	300	-180	170	75	

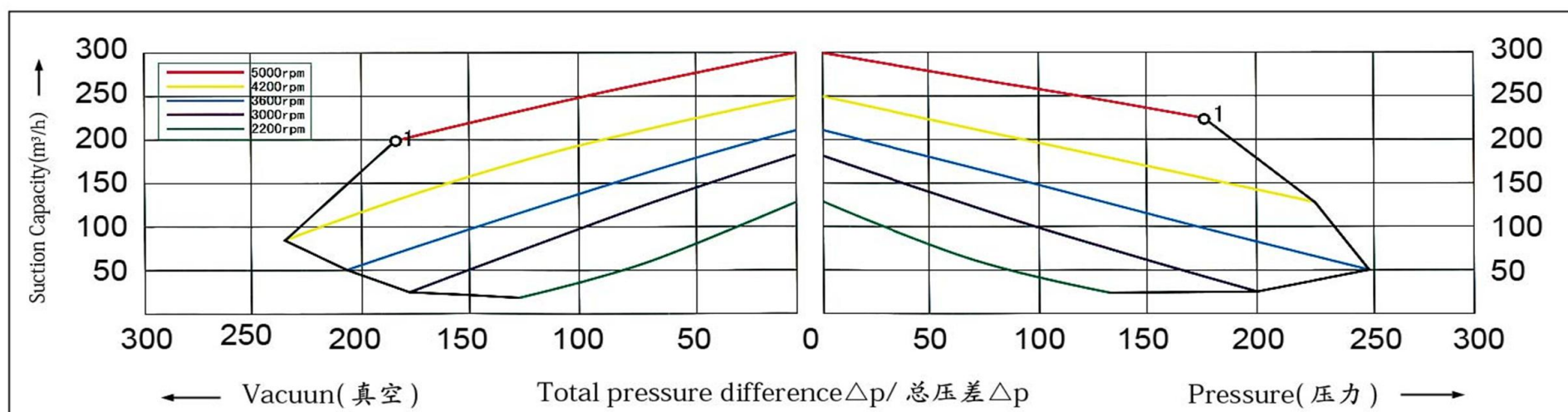

2HB 510-1HY99 参数及曲线

2HB 510-1HY99 parameters and the curve

NO	Rated Speed	Rated Power	Max air flow	Max vacuum	Max pressure	Sound-Level	Weight
编号	转速	配置功率	最大流量	最大真空	最大压力	噪音	重量
	PRM	KW	M ³ /h	mbar	mbar	db(A)	Kg
A	3000	1.3	210	-170	170	64	11
	3600	1.5	255	-150	140	70	
	4200	1.75	300	-130	100	72	
	5000	2.1	350	-70	60	75	
B	3000	1.6	210	-200	190	64	
	3600	2.05	255	-220	210	70	
	4200	2.3	300	-180	170	72	
	5000	2.6	350	-130	120	75	
C	3000	2.2	210	-220	270	64	
	3600	2.55	255	-260	290	70	
	4200	3	300	-300	270	72	
	5000	3.8	350	-270	240	75	

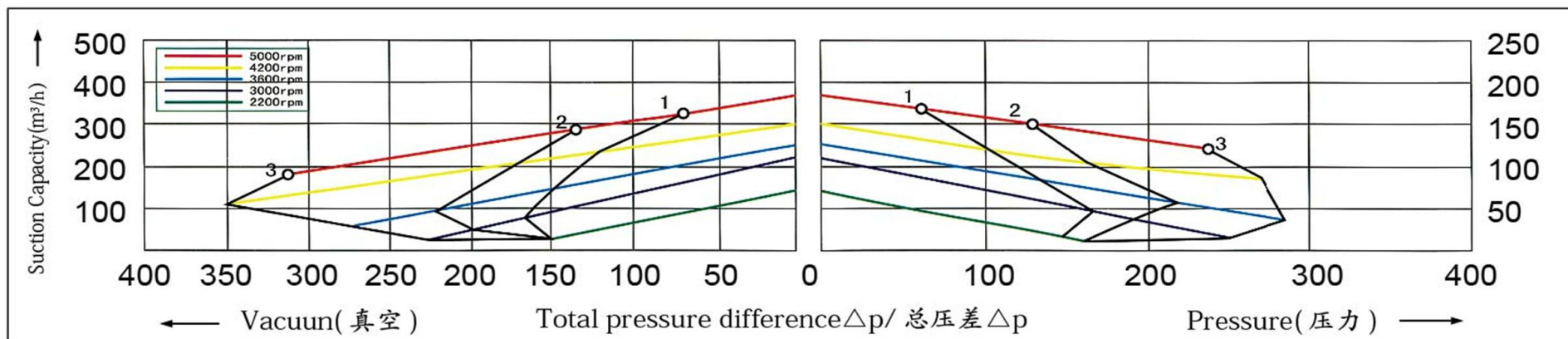

2HB 520-1HY99 参数及曲线

2HB 520-1HY99 parameters and the curve

NO	Rated Speed	Rated Power	Max air flow	Max vacuum	Max pressure	Sound-Level	Weight
编号	转速	配置功率	最大流量	最大真空	最大压力	噪音	重量
	PRM	KW	M ³ /h	mbar	mbar	db(A)	Kg
A	3000	3	230	-340	410	72	21
	3600	3.45	275	-380	360	74	
	4200	4.3	320	-340	300	78	
	5000	5	380	-300	240	83	
B	3000	4	230	-390	440	72	
	3600	4.6	275	-410	480	74	
	4200	6	320	-440	480	78	
	5000	6.9	380	-460	410	83	

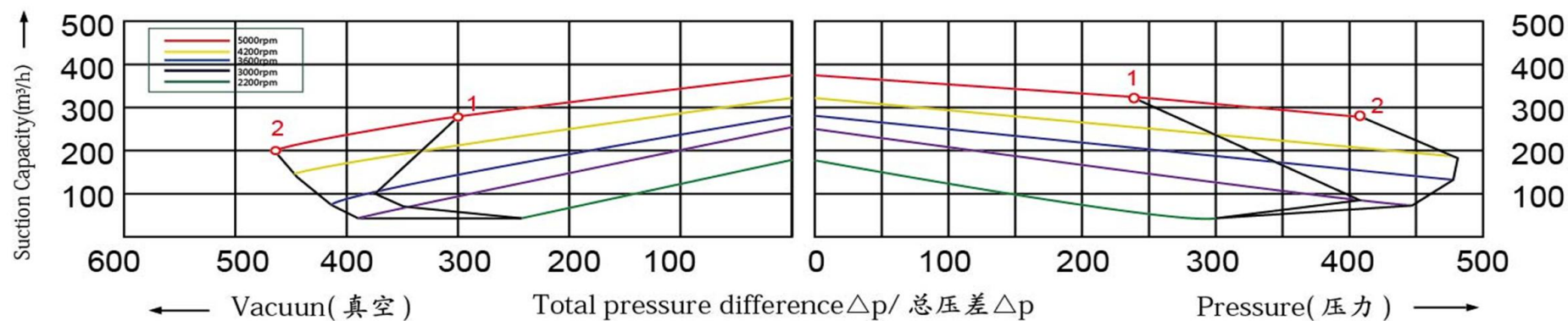

2HB 530-1HY99 参数及曲线 2HB 530-1HY99 parameters and the curve

NO	Rated Speed	Rated Power	Max air flow	Max vacuum	Max pressure	Sound-Level	Weight
编号	转速	配置功率	最大流量	最大真空	最大压力	噪音	重量
	PRM	KW	M ³ /h	mbar	mbar	db(A)	Kg
A	3000	2.2	270	-220	230	65	12
	3600	2.55	330	-260	250	71	
	4200	3	390	-270	250	73	
	5000	3.8	460	-230	220	76	

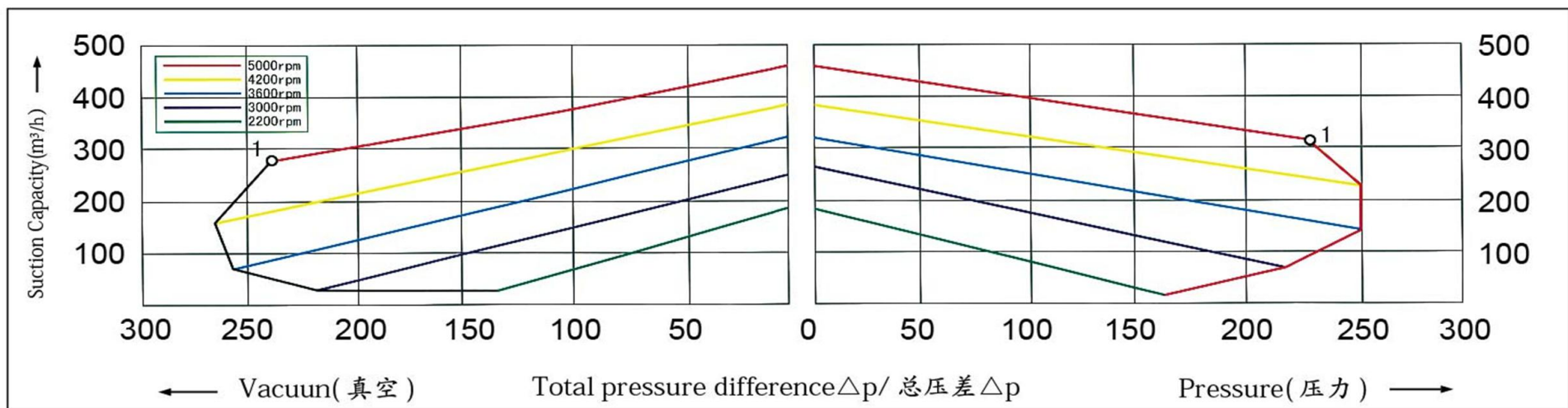

2HB 710-1HY99 参数及曲线

2HB 710-1HY99 parameters and the curve

NO	Rated Speed	Rated Power	Max air flow	Max vacuum	Max pressure	Sound-Level	Weight
编号	转速	配置功率	最大流量	最大真空	最大压力	噪音	重量
	PRM	KW	M ³ /h	mbar	mbar	db(A)	Kg
A	3000	2.2	320	-190	190	69	16
	3600	2.55	380	-190	190	72	
	4200	3	440	-160	160	75	
	5000	3.8	530	-130	130	80	
B	3000	3	320	-260	270	64	
	3600	3.45	380	-240	230	70	
	4200	4.3	440	-270	220	72	
	5000	5	530	-220	210	75	
C	3000	4	320	-290	360	64	
	3600	4.6	380	-320	310	70	
	4200	6	440	-340	300	72	
	5000	6.9	530	-300	270	75	

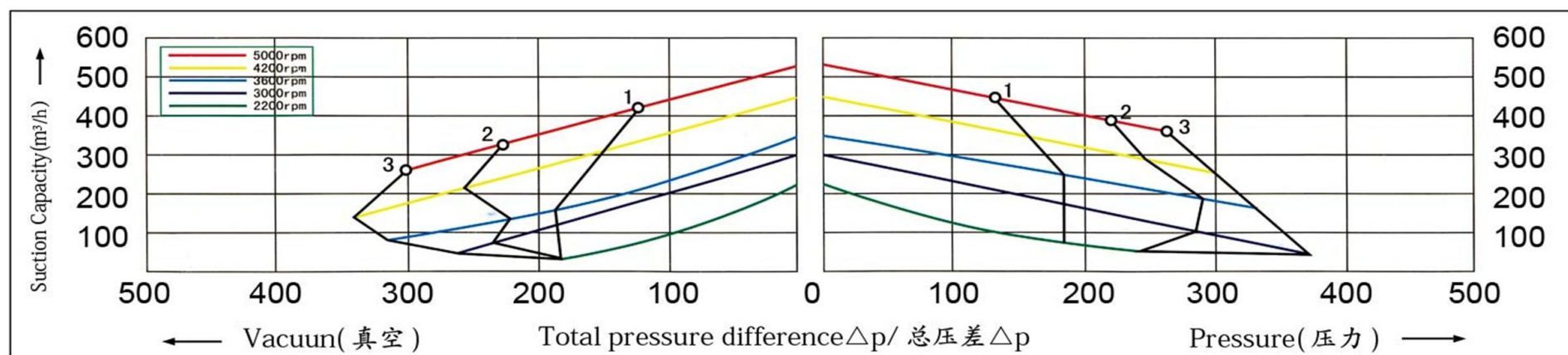

2HB 720-1HY99 参数及曲线 2HB 720-1HY99 parameters and the curve

NO	Rated Speed	Rated Power	Max air flow	Max vacuum	Max pressure	Sound-Level	Weight
编号	转速	配置功率	最大流量	最大真空	最大压力	噪音	重量
	PRM	KW	M ³ /h	mbar	mbar	db(A)	Kg
A	3000	4.3	320	-360	380	73	29
	3600	4.8	380	-350	320	75	
	4200	6.3	440	-310	300	78	
	5000	6.9	530	-240	200	84	
B	3000	5.5	320	-420	500	73	
	3600	6.3	380	-440	500	75	
	4200	7.5	440	-440	420	78	
	5000	8.8	530	-440	350	84	
C	3000	7.5	320	-440	570	73	
	3600	8.6	380	-460	660	75	
	4200	10	440	-460	600	78	
	5000	12	530	-440	400	84	

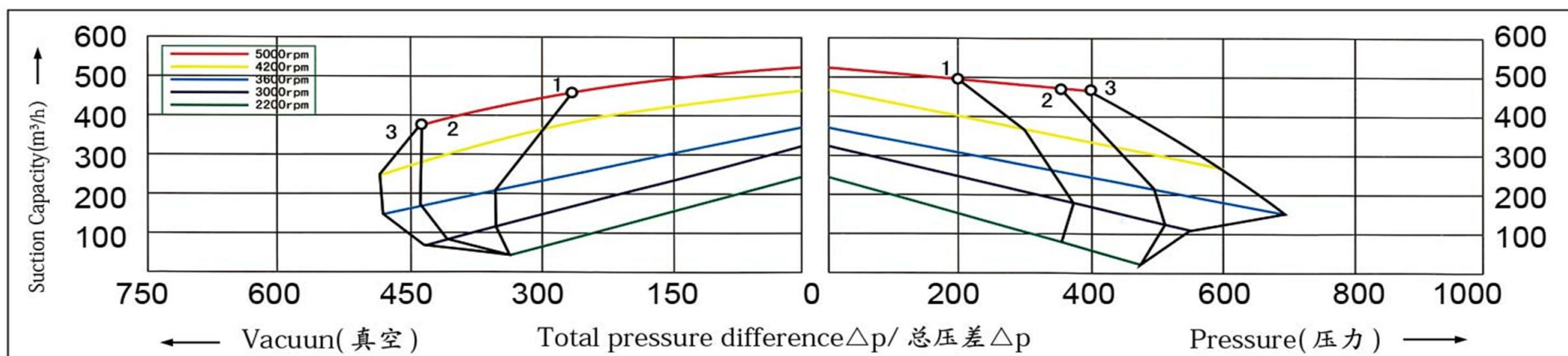

2HB 730-1HY99 参数及曲线

2HB 730-1HY99 parameters and the curve

NO	Rated Speed	Rated Power	Max air flow	Max vacuum	Max pressure	Sound-Level	Weight
编号	转速	配置功率	最大流量	最大真空	最大压力	噪音	重量
	PRM	KW	M ³ /h	mbar	mbar	db(A)	Kg
A	3000	2.2	420	-180	170	70	18
	3600	2.55	500	-160	150	73	
	4200	3	580	-140	130	76	
	5000	3.8	660	-120	120	81	
B	3000	3	420	-220	200	70	
	3600	3.45	500	-200	170	73	
	4200	4.3	580	-180	170	76	
	5000	5	660	-150	160	81	
C	3000	4	420	-260	290	70	
	3600	4.6	500	-260	260	73	
	4200	6	580	-260	260	76	
	5000	6.9	660	-260	250	81	

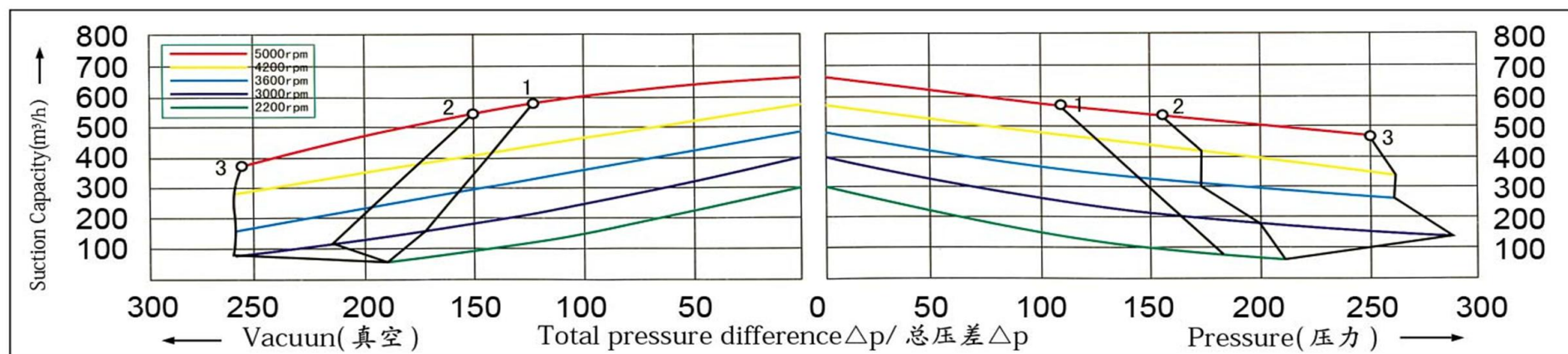

2HB 810-1HY99 参数及曲线 2HB 810-1HY99 parameters and the curve

NO	Rated Speed	Rated Power	Max air flow	Max vacuum	Max pressure	Sound-Level	Weight	Vacuum relief
编号	转速	配置功率	最大流量	最大真空	最大压力	噪音	重量	Items x type
	PRM	KW	M ³ /h	mbar	mbar	db(A)	Kg	2BX
1	3000	4.0	530	-200	200	73	38	1X...4740/...4840
	3600	4.6	620	-160	160	75		
	4200	6.0	720	-150	150	78		
	5000	6.9	830	-140	140	84		
2	3000	5.5	530	-300	300	73		
	3600	6.3	620	-300	280	75		
	4200	7.5	720	-280	260	78		
	5000	8.8	830	-220	210	84		
3	3000	7.5	530	-320	430	73		
	3600	8.6	620	-350	400	75		
	4200	10.0	720	-320	370	78		
	5000	12.0	830	-270	330	84		

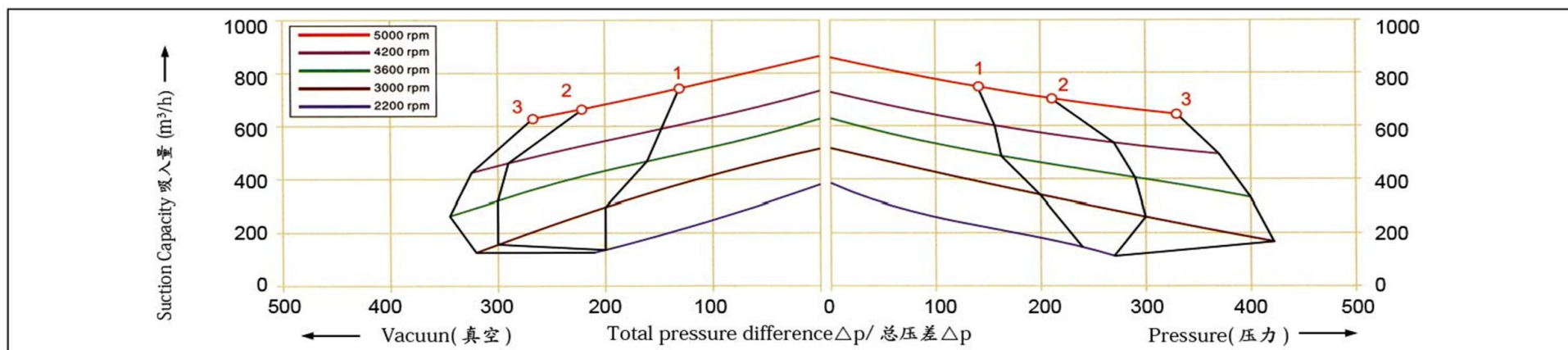

2HB 820-1HY99 参数及曲线

2HB 820-1HY99 parameters and the curve

NO	Rated Speed	Rated Power	Max air flow	Max vacuum	Max pressure	Sound-Level	Weight	Vacuum relief
编号	转速	配置功率	最大流量	最大真空	最大压力	噪音	重量	Items x type
	PRM	KW	M ³ /h	mbar	mbar	db(A)	Kg	2BX
1	3000	7.5	520	-400	400	74	64	1X...4740/...4840
	3600	8.6	620	-360	330	78		
	4200	10.0	730	-240	220	81		
	5000	12.0	860	-100	80	84		
2	3000	11.0	520	-430	600	74		
	3600	12.6	620	-460	600	78		
	4200	14.5	730	-480	360	81		
	5000	17.6	860	-440	290	84		
3	3000	15.0	520	-460	670	74		
	3600	17.3	620	-490	750	78		
	4200	21.0	730	-480	680	81		
	5000	24.0	860	-440	520	84		

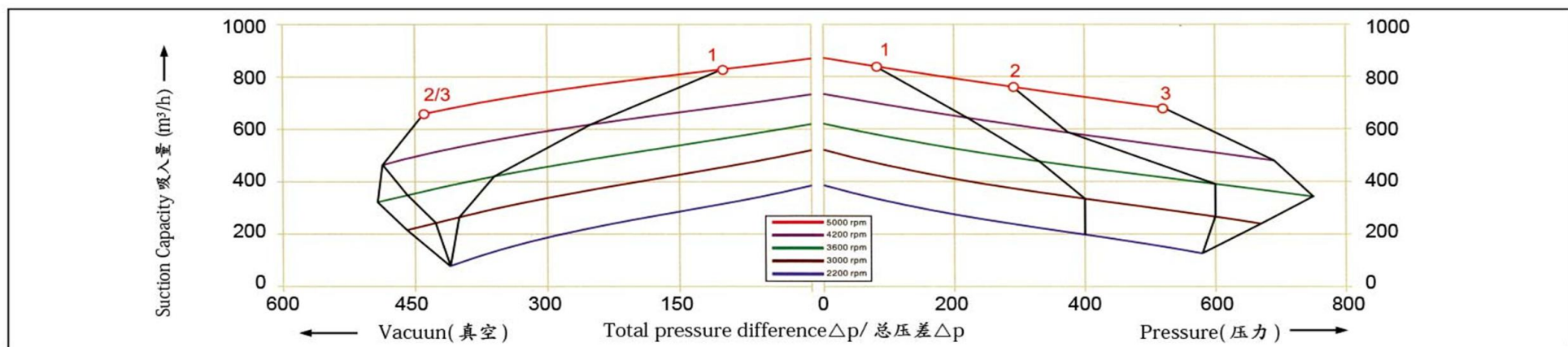

2HB 910-1HY99 参数及曲线 2HB 910-1HY99 parameters and the curve

NO	Rated Speed	Rated Power	Max air flow	Max vacuum	Max pressure	Sound-Level	Weight	Vacuum relief
编号	转速	配置功率	最大流量	最大真空	最大压力	噪音	重量	Items x type
	PRM	KW	M ³ /h	mbar	mbar	db(A)	Kg	2BX
1	3000	8.5	1050	-190	190	74	72	1X...750/...860
	3600	9.8	1250	-150	140	79		
	4200	12.0	1400	-60	80	82		
2	3000	12.5	1050	-290	280	74		
	3600	14.5	1250	-270	260	79		
	4200	17.5	1400	-250	240	82		
3	3000	18.5	1050	-360	460	74		
	3600	21.3	1250	-380	420	79		
	4200	26.0	1400	-400	400	82		

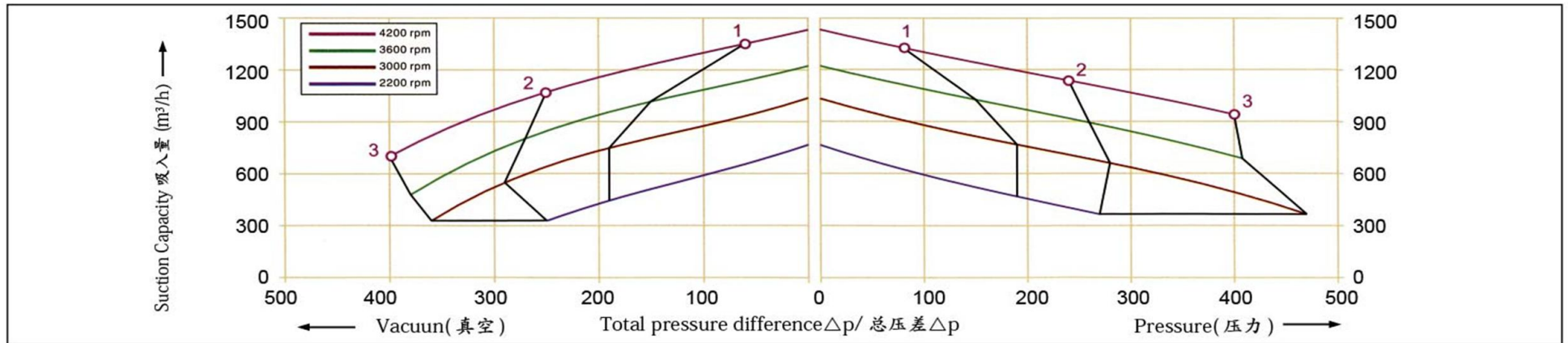

2HB 920-1HY99 参数及曲线

2HB 920-1HY99 parameters and the curve

NO	Rated Speed	Rated Power	Max air flow	Max vacuum	Max pressure	Sound-Level	Weight	Vacuum relief
编号	转速	配置功率	最大流量	最大真空	最大压力	噪音	重量	Items x type
	PRM	KW	M ³ /h	mbar	mbar	db(A)	Kg	2BX
1	3000	12.5	1110	-300	270	74	110	2X...750/...860
	3600	14.5	1310	-220	200	84		
	4200	17.5	1600	-150	130	87		
2	3000	16.5	1110	-410	370	74		
	3600	19.0	1310	-340	300	84		
	4200	21.0	1600	-270	240	87		
3	3000	20.0	1110	-440	500	74		
	3600	23.0	1310	-440	430	84		
	4200	28.0	1600	-440	340	87		
4	3000	25.0	1110	-440	590	74		
	3600	29.0	1310	-440	540	84		
	4200	35.0	1600	-460	460	87		

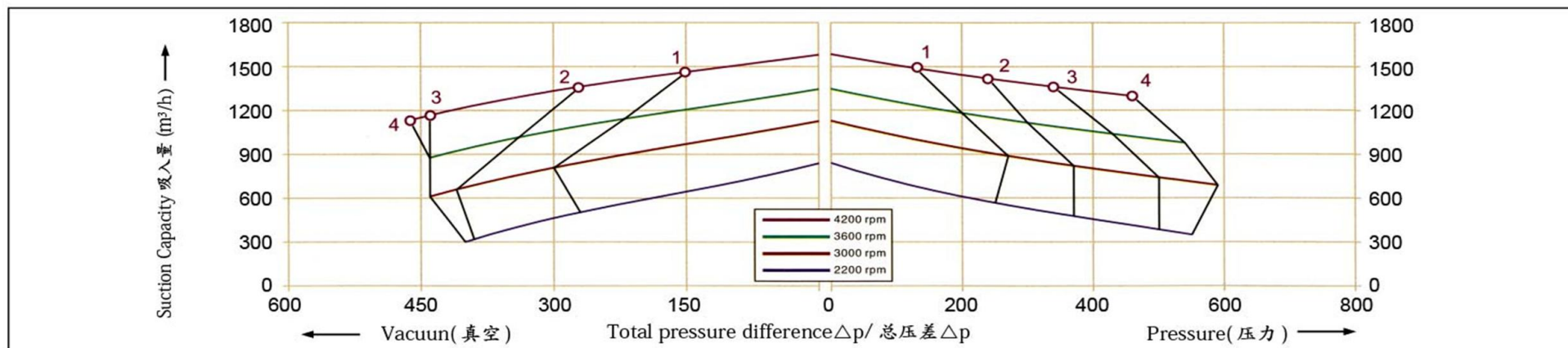

皮带式高压风机安装尺寸 Single-stage pump Dimension

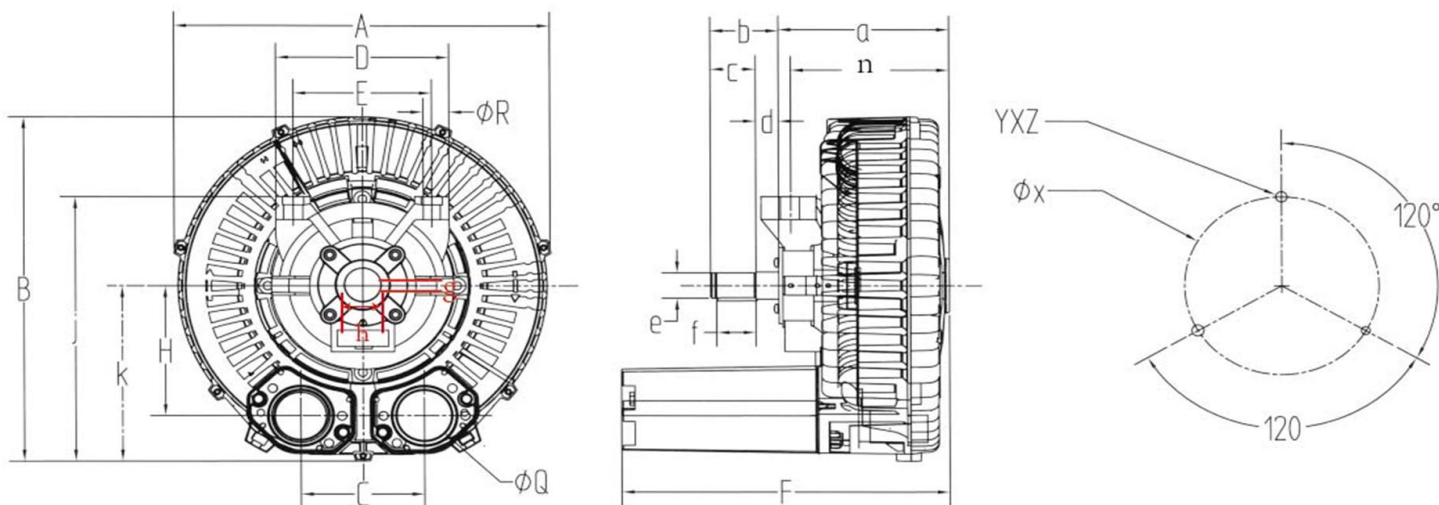

型号 Type	A	B	C	D	E	F	H	J	K	Q	R	a	b	c	d	e	f	g	h	n	yxz	x
2HB 210-1HY99	246	240	90	157	125	230	89	211	125	40	14	140	51	43	2	24	40	8	20	128	M6X15	140
2HB 230-1HY99	246	240	90	157	125	241	89	211	125	40	14	151	51	43	2	24	40	8	20	139	M6X15	140
2HB 410-1HY99	286	300	115	157	125	240	108	233	148	45	14	143	53	43	2	24	40	8	20	130	M6X15	174
2HB 430-1HY99	286	300	115	157	125	256	108	233	148	45	14	159	53	43	2	24	40	8	20	146	M6X15	174
2HB 510-1HY99	334	324	120	177	140	297	127	268	169	55	18	169	60	44	2	28	40	8	24	156	M8X20	200
2HB 530-1HY99	334	324	120	177	140	316	127	268	169	55	18	188	60	44	2	28	40	8	24	175	M8X20	200
2HB 610-1HY99	360	358	122	177	140	318	135	281	183	55	18	175	60	44	2	28	40	8	24	163	M8X20	226
2HB 630-1HY99	360	358	122	177	140	336	135	281	183	55	18	193	60	44	2	28	40	8	24	181	M8X20	226
2HB 710-1HY99	382	382	125	177	140	333	144	292	194	55	18	182	60	44	2	28	40	8	24	169	M10X20	240
2HB 730-1HY99	382	382	125	177	140	343	144	292	194	55	18	192	60	44	2	28	40	8	24	179	M10X20	240
2HB 810-1HY99	451	461	152	245	195	433	175	265	230	68	24	227	85	78	2	42	60	12	37	210	M12X20	286

皮带式高压风机安装尺寸 Single-stage pump Dimension

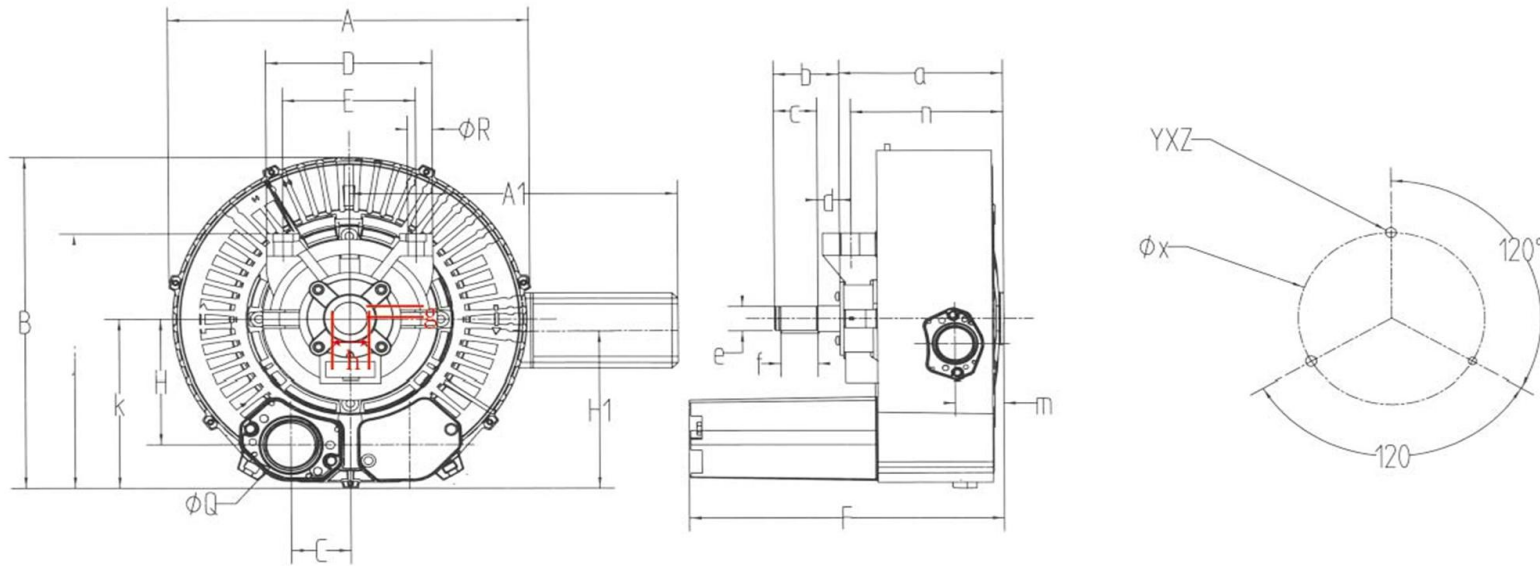

型号 Type	A	B	C	D	E	F	H	J	K	Q	R	A1	H1	a	b	c	d	e	f	g	h	m	n	yxz	x
2HB 220-1HY99	285	270	45	157	125	288	89	214	128	40	14	217	106	199	51	43	2	24	40	8	20	42	186	M6X15	140
2HB 320-1HY99	297	289	46	157	125	302	100	227	141	40	14	323	114	209	51	43	2	24	40	8	20	46	196	M6X15	160
2HB 420-1HY99	322	315	58	157	125	316	108	240	154	45	14	322	153	219	53	43	2	24	40	8	20	46	207	M6X15	174
2HB 520-1HY99	371	361	60	177	140	383	127	275	175	55	18	411	145	255	60	44	2	28	40	8	24	55	241	M8X20	200
2HB 720-1HY99	426	421	63	177	140	429	144	295	197	55	18	426	162	278	60	44	2	28	40	8	24	75	265	M10X20	240
2HB 820-1HY99	500	500	76	245	195	545	175	365	230	68	24	549	195	240	85	78	2	42	60	12	37	84	322	M12X20	286

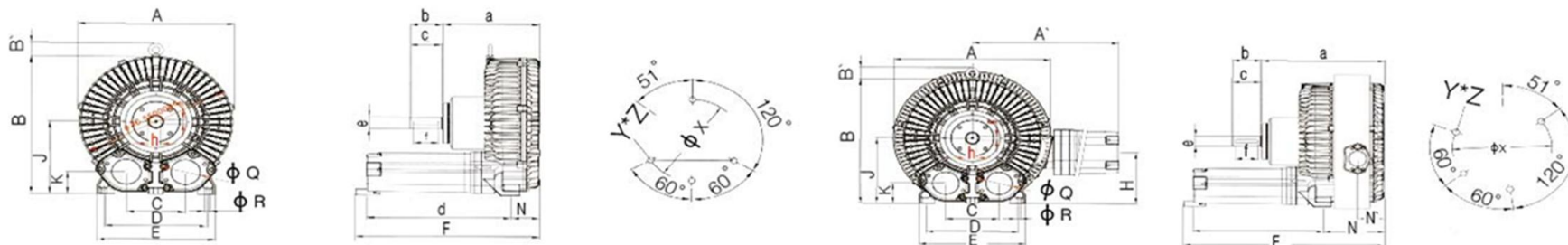

型号 Type	A	B	B'	C	D	E	F	J	K	N	φQ	φR
2HB 910-1HY99	550	569	55	207	360	415	644	300	92	127	100	15
型号 Type	a	b	c	d	e	f	h	g	Y*Z	φX		
2HB 910-1HY99	340	114	110	533	48	90	42	14	M12x30	490		

型号 Type	A	A'	B	B'	C	D	E	F	J	H	K	N	N'
2HB 920-1HY99	615	780	569	55	207	360	415	785	300	234	92	230	113
型号 Type	a	b	b	d	e	f	h	g	Y*Z	φX	φQ	R	
2HB 920-1HY99	480	114	110	533	48	90	42	14	M12x30	490	100	15	